

Pure competence in air.

NOVENCO BUILDING & INDUSTRY

PURE COMPETENCE IN AIR

Building & Industry



SCHAKO Group

ESSENCE

Our consideration for the environment in the design and manufacturing of ventilation equipment and fans is a big concern for us. The resource friendly products reflect this dedication with long service life and environmentally safe production.

ABOUT US

NOVENCO Building & Industry was founded 1947 in Denmark, and today is a proud member of SCHAKO Group. We manufacture a wide range of efficient and reliable products and systems for ventilation in our 20.000 m² production facility. The company counts approximately 200 employees and is continuously expanding. Our parent company is located in Naestved, Denmark, with subsidiaries in The Netherlands. We also have offices in Germany, United Kingdom and Dubai. Furthermore, our products and services are marketed and distributed through a network of subsidiaries and carefully chosen representatives.

INNOVATION

Since the beginning our design, development and operation of ventilation products and systems have allowed us to amass vast experience. The efforts we put into research and development reflect our dedication and allow us to create products on the technological forefront with respect to performance and durability. This is what we consider necessary to stay in front in a world that changes constantly with new environment requirements and calls for innovative solutions from customers and the business environment. These challenges fuel our desire to create the next generation of ventilation products.

GREEN FOCUS

The land based applications and markets are the focal point of our business. For these markets we develop and implement high efficient ventilation fans which require minimal resources to run and still be able to reduce the discharge of harmful substances. The carparks segment is a core business, which we in the 1990s revolutionised with our jet fans. These fans play central roles in a growing number of installations. Even in such critical situations as with fires, the environment remains in focus, as the amount of energy for the systems is minimum. This true 2-in-1 system feature protects lives and spares the environment.

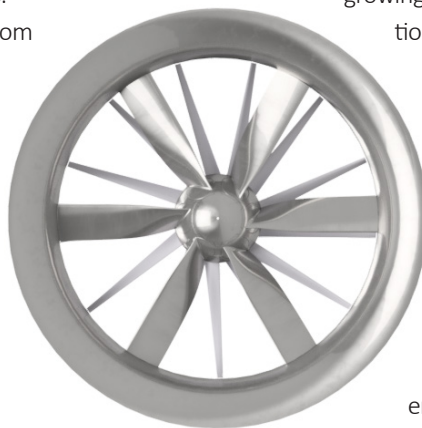

QUALITY AND ENVIRONMENT

The production facilities are located in Denmark and are in agreement with the environmental standards according to ISO 9001 and ISO 14001. We lower the strain put on the environment as we reduce energy consumption, improve waste sorting, minimise steel scrap and evaluate our product range and suppliers from an environmental point of view. The effort it takes to serve the environment and markets with the right products is a constantly growing challenge we commit ourselves to every day. All products and systems are certified in accordance with ISO 9001:2008 and ISO 14001:2004.



SOLUTIONS

Addressing the market in a solution-based approach is an integral and deep-rooted approach for NOVENCO Building & Industry. Since the establishment of the company, the goal has been to design and implement solutions for a wide range of industries. To begin with, the focus was on providing basic ventilation within fields such as agriculture, stable ventilation, greenhouses and residential buildings. Over the years, this has expanded to cooling applications, car park ventilation and data centres etc. By working through a range of different projects, we have built up a vast amount of experience and gained a strong reputation for air handling, ventilation and natural cooling. We possess the expertise to understand business requirements, and we have the products to supply the best solutions.



AGRICULTURE

Agriculture focuses on environmental and energy saving solutions for farms, culture, dairy and industrial facilities. Our innovative products and designs help ensure optimum ventilation and comfort in this vital industrial sector. The solutions are proven and can substantially increase productivity and reduce health issues at very low investment and operating cost. Our products and knowledge also provide perfect storage conditions and therefore the losses through wastes are reduced.

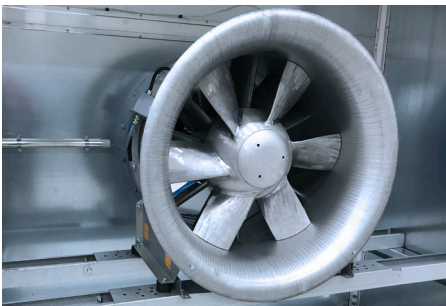

AHU FANS

The AHU (air handling unit) Fans combine high performance and small space requirements. Our AHU Fans meet both of these requirements and offer energy savings up to 50% and ROIs down to 1 year when replacing fans in existing AHUs. With the ZerAx® axial fans the efficiencies are up to 92% and noise levels are significantly lower compare to other manufacturers. Because of the high efficiencies, it is quite often possible to design smaller AHUs with the same performance characteristics and hence to cut down on capital expenditure.



BUILDINGS

NOVENCO Building & Industry covers energy efficient ventilation for all categories of buildings. These solutions are innovative and meet the demands for low energy consumption and running cost while providing comfortable and healthy indoor environments. Our products are installed in commercial, industrial, public and residential buildings all over the world.

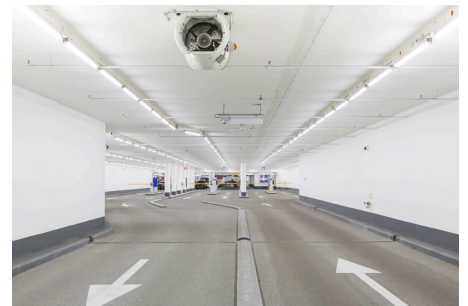

CAR PARKS

The Car Parks solutions build on our fundamental technologies and expertise. This field of solutions was founded in the 1990s when our jet fans revolutionised the market for car parks. The jet fans have long since shown to be invaluable assets for removal of exhaust gases from cars and for aiding in firefighting. The amount of energy is minimum in all situations, when providing comfort ventilation or when aiding in removing toxic smoke from fires. The solutions are truly 2-in-1 as they help protect lives, assets, and the environment.



COOLING

Our cooling solutions are based primarily on the natural cooling principle, i.e. removal and replacement of hot air with fresh air from the outdoors, when low temperatures are necessary we can find a solution in combining natural and mechanical cooling. All these solutions are characterised by low service requirements, maintenance, energy cost, as well as long lifetimes. Consequently, the payback on the capital cost is often very impressive.



DATA CENTRES

This area is relatively new and exciting as the need for cooling server farms is growing rapidly. Centres often consume huge energy amounts and experience real risks of overheating. The ZerAx® generation of axial flow fans meet these unique requirements for top-range performance with efficiencies above 90% and low power consumption.



DRYING

This area focuses on the wood, manufacturing-process industries and agriculture. Our solutions for drying freshly cut wood reduce the moisture content and keep the wood from warping, cracking and becoming distorted. The benefits are obvious as the amount of discarded wood is greatly reduced. By agriculture crops the moisture content is regulated and therefore the waste reduced and the quality improved.



EC+

Conceived to increase efficiency of HVAC systems, the EC+ concept offers to radically reduce use of energy in new build AHU's and in existing systems. The concept prescribes components for optimum system design - permanent magnet (PM) motors, Danfoss VLT® frequency drives and NOVENCO's high efficient ZerAx® axial flow fans - which has the potential to deliver system efficiencies in the range of 80 – 85%.



ENERGY EFFICIENCY

This area is of great importance to us. Our ambition is to be on the technological forefront when it comes to energy and cost-efficient ventilation. We focus on sustainability in construction and are proud to have launched products that meet consumer demands and the environmental standards of tomorrow.



EXPLOSIVE ENVIRONMENT

This area focuses on ventilation for industries with high safety requirements due to risks of explosions and fire. Typically, this includes refineries and other industries with high concentrations of gases and dust. The products are well-proven with ATEX-approved motors, all-welded fan housings, brass-linings and more.



MUSHROOM CULTIVATION AND GREENHOUSES

This area builds on our long experience of delivering specific solutions. The ventilation systems in the mushroom cultivation and greenhouses ensure optimum conditions. Factors like precise control of temperature, humidity, CO₂-content and air circulation in

combination with low energy and maintenance costs put high demands on the ventilation system and are important to ensure the best yield compared to the lowest costs.



PRESSURE DIFFERENTIAL SYSTEMS

This area provides systems for creating smoke barriers that allow people to escape buildings and tunnels, and aid the firefighting services. The system holds back smoke at porous physical barriers such as doors or other similar restricted openings. The field of application differs from a variety of buildings and tunnels where there is a need to protect means of escape such as stairwells, corridors, escape tunnels, lobbies, as well as for providing bridgeheads for the firefighting services.



PROCESS INDUSTRY

This area requires tough and robust solutions. Our ventilation products are purpose-built to withstand the rigours of modern industrial environments and can be installed in corrosive areas, as part of processing systems or for combustion processes.



RETROFITS

In this area, we aim at reducing energy consumption of existing installations. Secondly, and perhaps more importantly, the goal is to reduce the strain on the environment by minimising the discharge of CO₂. The climate in large industrial buildings is often improved considerably when for example the ventilation system is retrofitted with our innovative solutions.



SMOKE CONTROL

This area provides products and systems for extracting smoke and fume gases of accidentally fires. The system extract the toxic smoke and hot fumes from enclosed areas to ensure the possibility to escape from these areas and to ensure a safe access for the emergency services. Our knowledge, experience and simulation software provides the best solutions. The products are tested and approved according to international standards.



TUNNELS

This area builds on our years of experience with design and implementation of tunnel ventilation through all project phases. Our expertise and products are suited for all kinds and sizes of tunnels.



WIND INDUSTRY

This area is our latest and fastest growing market. The clean and renewable energy source that wind energy represents sets new standards for fan efficiency and durability. Our products and designs are already part of big and small installations all over the world.

PRODUCTS

NOVENCO Building & Industry manufactures a wide range of products and systems for ventilation. The products and systems are build on our experience and deliver superb reliability with low energy consumption.



AIR HEATERS

Represent an ideal solution for installation of heat systems in rooms and buildings where centrally controlled systems with long ductworks are needlessly expensive or even unsuitable. Typical applications are in industrial buildings, workshops, halls, warehouses, large sports centers etc.

The NOVENCO NoVa air heater system is water-based with five standard units composed of heating coils and axial flow fans fitted in cabinets. The system is configurable for many kinds of room layouts through a wide range of accessories.

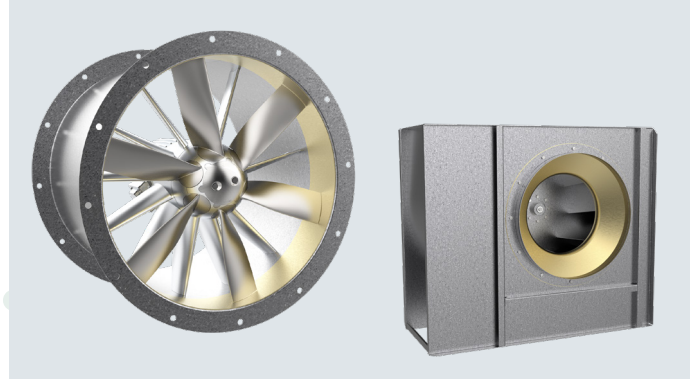

ATEX FANS

ATEX fans are axial flow fans optimised for installation in hazardous environments with high requirements for safety.

The ZerAx® fans for ATEX or EX uses are compact, robust and well suited for operation in conditions unhealthy for humans. They display the same qualities as the standard versions.

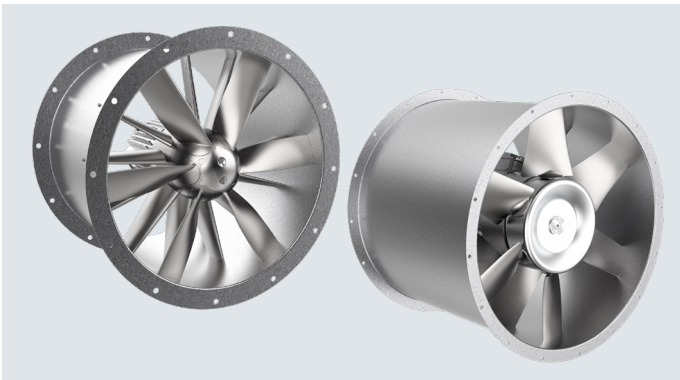

AXIAL FLOW FANS

Axial flow fans are for very diverse applications within almost all sectors on land and offshore. Often fans are part of systems for comfort, industrial air handling, process, parking, tunnel ventilation. The ZerAx® fans are the latest addition to the NOVENCO fan range. They build on the still-produced NovAx fans, and set new standards for what is possible with respect to efficiency and return-on-investments. The design reflects the efficiency in every detail and lends from the aviation industry.

The NovAx fans are classical in design and have performance that still is among the best in the industry. ZerAx® and NovAx fans are available in versions for duct installation, AHU integration, heavy-duty, hot smoke and demanding marine use.



CAR PARK FANS

Car Park fans are for ventilation and fire control in roofed facilities like underground car parks, carpark tower blocks etc. The system is unique as it is without ducts and uses the impulse principle to move air. Often the designs include axial flow fans for supply or exhaust air. The advantages are lower construction cost and better space utilisation.

The NOVENCO Car Park fans series are available as unidirectional or reversible units and include versions with silencers or with silencing technology. Designs are oval, round or flat.

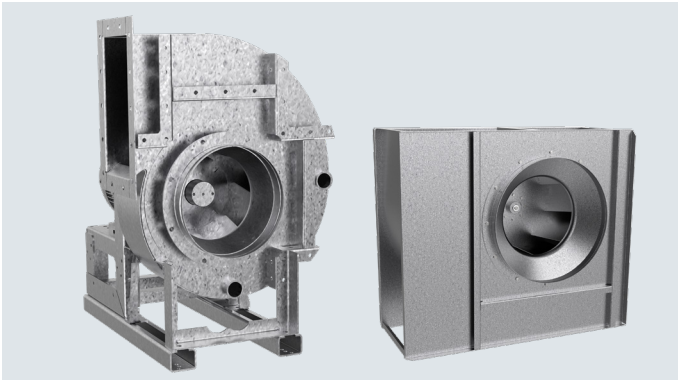

CENTRIFUGAL FANS

Centrifugal fans are for industrial installations, which require low or medium pressures. Facilities like composting plants and greenhouses are examples of industries that use centrifugal fans.

The design is robust, compact and suited to meet the requirements for long-life, service in corrosive environments and continuous operation.



SMOKE FANS

Smoke fans are axial flow fans optimised for operation in high temperature conditions. Typical use is as exhaust fans installed in ducts, where they double-function as part of normal operation and as smoke exhaust fans. The fans are compact, robust and approved for operation at 300 or 400 °C.

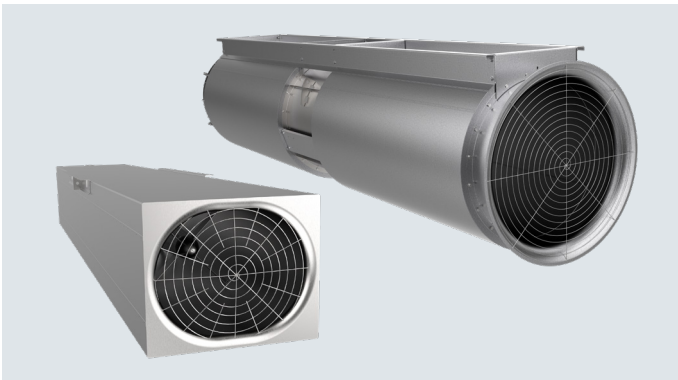

TUNNEL FANS

Tunnel fans are for ventilation and fire control in tunnel facilities.

The units use the impulse principle to move air through the tunnels, which then function as oversized ducts. Some system designs include axial flow fans for supply or exhaust. Ventilation with tunnel fans have low construction cost and good space utilisation.

The NOVENCO Tunnel fans series are available as unidirectional or reversible units with silencers. Designs are square or round.

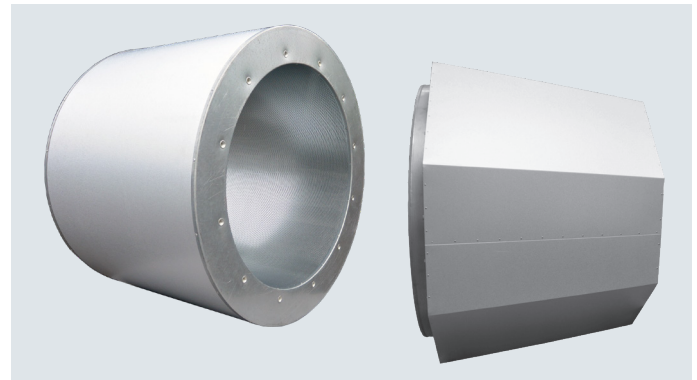

ACCESSORIES:

DAMPERS

NOVENCO dampers are used in both ventilation systems and air handling installations. The design is in aluminum.

DIFFUSERS

NOVENCO diffusers are robust in design and available for almost all axial flow fans.

SILENCERS

NOVENCO silencers are available with or without cores, which provide ample possibilities for designing optimum solutions. Versions with cores are for removing high-frequency sounds.

Both hot-dip galvanised and acid-resistant executions are available.

SCHAKO PRODUCTS



DIFFUSERS

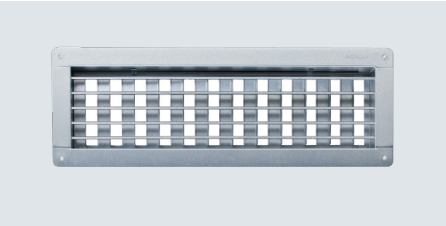
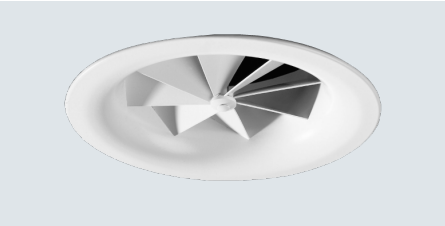

GRILLS

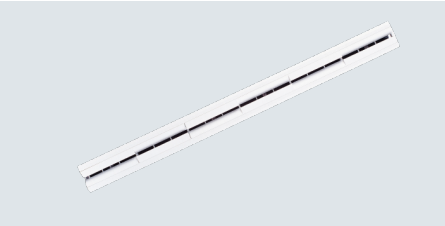

DAMPERS

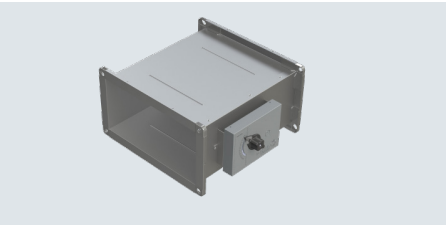
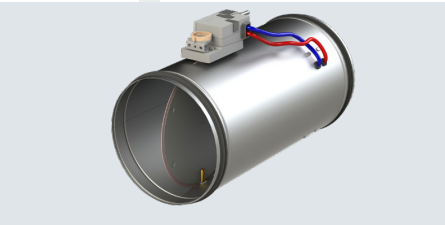

FLOW REGULATORS

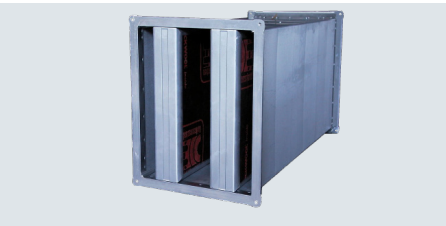

SILENCERS AND BAFFLE PLATES

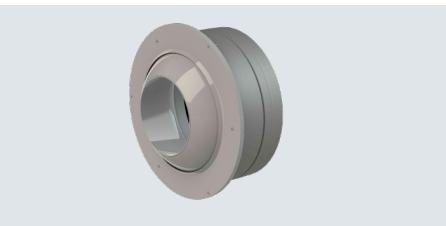

NOZZLES

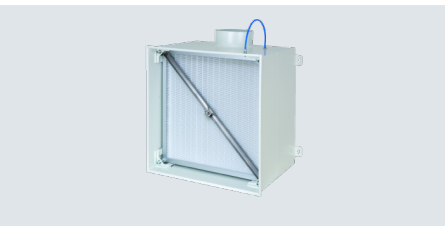

CLEAN ROOM UNITS

REFERENCES



BURJ KHALIFA (DUBAI, UAE)



CARLSBERG (FREDERICIA, DENMARK)



TÜV SÜD (OLCHING, GERMANY)



KVAESTHUS (COPENHAGEN, DENMARK)



WESTGATE OXFORD (OXFORD, GREAT BRITAIN)



AXEL TOWERS (COPENHAGEN, DENMARK)

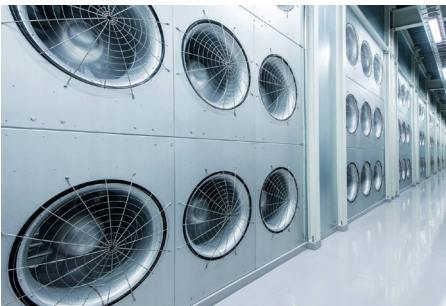

DATA CENTRE (SWEDEN)



DATA CENTRE (DENMARK)



BMW WELT (MUNICH, GERMANY)



KING WILLEM ALEXANDER TUNNEL
(THE NETHERLANDS)



DANISH TV STATION (COPENHAGEN, DENMARK)



EXPERIMENTARIUM (HELLERUP, DENMARK)



AIDA



SIEMENS GAMESA



VESTAS

REFERENCES



JK TYRES (INDIA)



BLOX (COPENHAGEN, DENMARK)



OUH (ODENSE, DENMARK)



GREENWICH WHARF (LONDON, UK)



AL RASHID MALL (RIYADH, SAUDI ARABIA)



AARHUS CONCERT HALL (AARHUS, DENMARK)

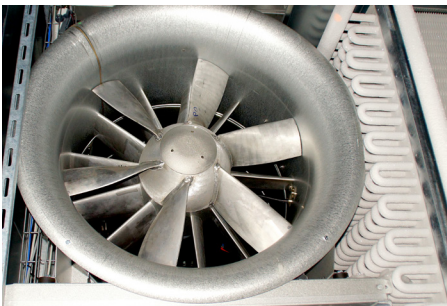

CS GRUPPEN (PADBORG, DENMARK)



NIEUW HOOG CATHARIJNE (UTRECHT, THE NETHERLANDS)



ADNOC HOUSING COMPLEX (RUWAIS, UAE)



CHIREC HOSPITAL (AUDERGHEM, BELGIUM)

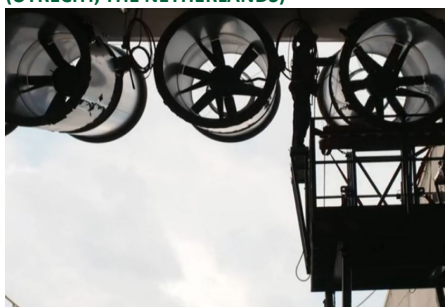

GAASPERDAMMERTUNNEL (THE NETHERLANDS)



SIMA POWER STATION (EIDFIJORD, NORWAY)

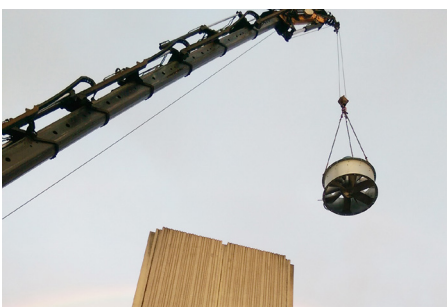

HVIDOVRE HOSPITAL (HVIDOVRE, DENMARK)



BRUSSELS AIRPORT (ZAVENTEM, BELGIUM)



ADNOC BACHELORS ACCOMMODATION (RUWAIS, UAE)

IMPORTANT

This document is provided 'as is'. NOVENCO Building & Industry A/S reserves the right to changes without further notice due to continuous product development.

Some pictures in the brochure show products with accessories fitted.

The fans are designed for continuous operation. The following kinds of operation may cause fatigue break in the impeller and endanger people.

- Operation in stall area
- Operation with pulsating counter pressure – called pump mode
- Daily operation with exceedingly starting and stopping

If in doubt, NOVENCO should be contacted to assess the suitability of the fan.

Copyright (c) 2002- 2018,
NOVENCO Building & Industry A/S.
All rights are reserved.

PATENTS AND TRADEMARKS

Novenco[®], 诺文科, 诺万科 and 诺芬 are registered trademarks of Novenco A/S or Novenco Marine & Offshore A/S.

ZerAx[®] is a registered trademark of Novenco A/S or NOVENCO Building & Industry A/S.

AirBox[™] and NovAx[™] are trademarks of NOVENCO Building & Industry A/S.

The ZerAx[®] manufacturing processes, technologies and designs are patented by Novenco A/S. **Pending patents** include Brazil no. BR-11-2012-008607-3, BR-11-

2012-008543-3, BR-11-2012-008545-0, BR-11-2014-002282-8 and BR-11-2014-002426-0; Canada no. 2.777.140, 2.843.131 and 2.843.132; China no. 2012280037965.7; EU no. 10778838.2, 12740606.4 and 12740612.2; India no. 4140/CHENP/2012, 4077/CHENP/2012, 4073/CHENP/2012, 821/CHENP/2014 and 825/CHENP/2014; PCT no. EP2012/064908 and EP2012/064928; South Korea no. 10-2012-7012252, 10-2012-7012154, 10-2012-7012155, 10-2014-7005746 and 10-2014-7003829; and US no. 14/234.654.

Pending designs include US no. 29/541.418 and 29/541.422.

Granted patents include Canada no. 2.777.141 and 2.777.144; China no. ZL2010800458842, ZL2010800460965, ZL2010800464275 and ZL2012800387210; EU no. 2488759 and 2488761; and US no. 8.967.983, 9.200.641, 9.273.696 B2 and 9,683,577. **Granted designs** include Brazil no. BR-30-2012-003932-0; Canada no. 146333; China no. 1514732, 1517779, 1515003, 1555664 and 2312963; EU no. 001622945-0001 to 001622945-0009 and 001985391-0001; India no. 246293; South Korea no. 30-0735804; and US no. D665895S, D683840S, D692119S, D704323S, D712023S, D743018S, D755363S and D756500S.

The NovAx Basic jet fans manufacturing processes, technologies and designs are patented by Novenco A/S or NOVENCO Building & Industry A/S. **Pending patents**

include United Arab Emirates no. 723/2011 and EU no. 10701831.9. **Pending designs**

include United Arab Emirates no. 223/2009.

Granted patents include Denmark no. PR 1774428. **Granted designs** include EU no. 001069884-0001 to 001069884-0028.

The CGF jet fans designs are patented by Novenco A/S. **Pending designs** include United Arab Emirates no. 70/2010.

Granted designs include EU no. 001610643-0001 to 001610643-0005.

Other trademarks appearing in this document are the property of their respective owners.

QUALITY AND ENVIRONMENT

NOVENCO Building & Industry A/S is certified in accordance with ISO 9001 and 14001.



All NOVENCO Building & Industry's products are designed, developed and manufactured in Denmark.



Pure competence in air.

mu 15687 1018

Building & Industry

NOVENCO 

SCHAKO Group

WWW.NOVENCO-BUILDING.COM